



**IMT**®

**A 45**

hydraulic drill rig

**IMT**®

**INVT.**



# A 45

IMT, a global leader in the manufacture of drill rigs and a brand which has always been synonymous with quality and reliability in the pursuit of satisfying market demand, is pleased to present a new series of A drill rigs. This new line is unique in its simplicity and flexibility of use, while also perfectly maintaining sturdiness and productivity.

The A45 is the most powerful and high-performance drilling rig in its market segment. Its evident Heavy Duty nature, given by the robustness of the drilling attachment, the widening track and the parallelogram system, in addition to the very high performance that has always distinguished us, make the A45 capable of operating in the most difficult terrain with excellent productivity.

Its compact size and ease of transport make the A45 the best machine in the world to operate in the most confined and difficult areas. Its multipurpose vocation allows it to quickly change working configuration; from LCA (Low Clearance Attachment) to CFA in a very short time.



# A 45 - Hydraulic Drill Rig

Crowd cylinder version

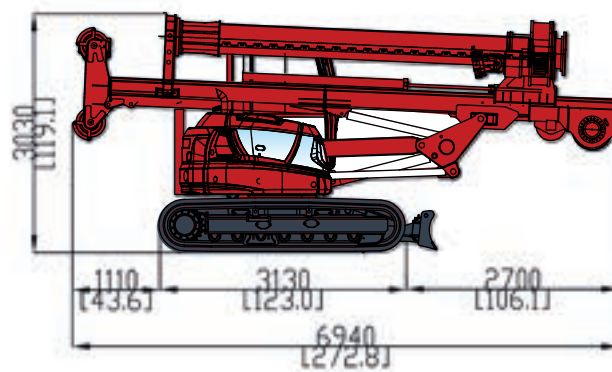
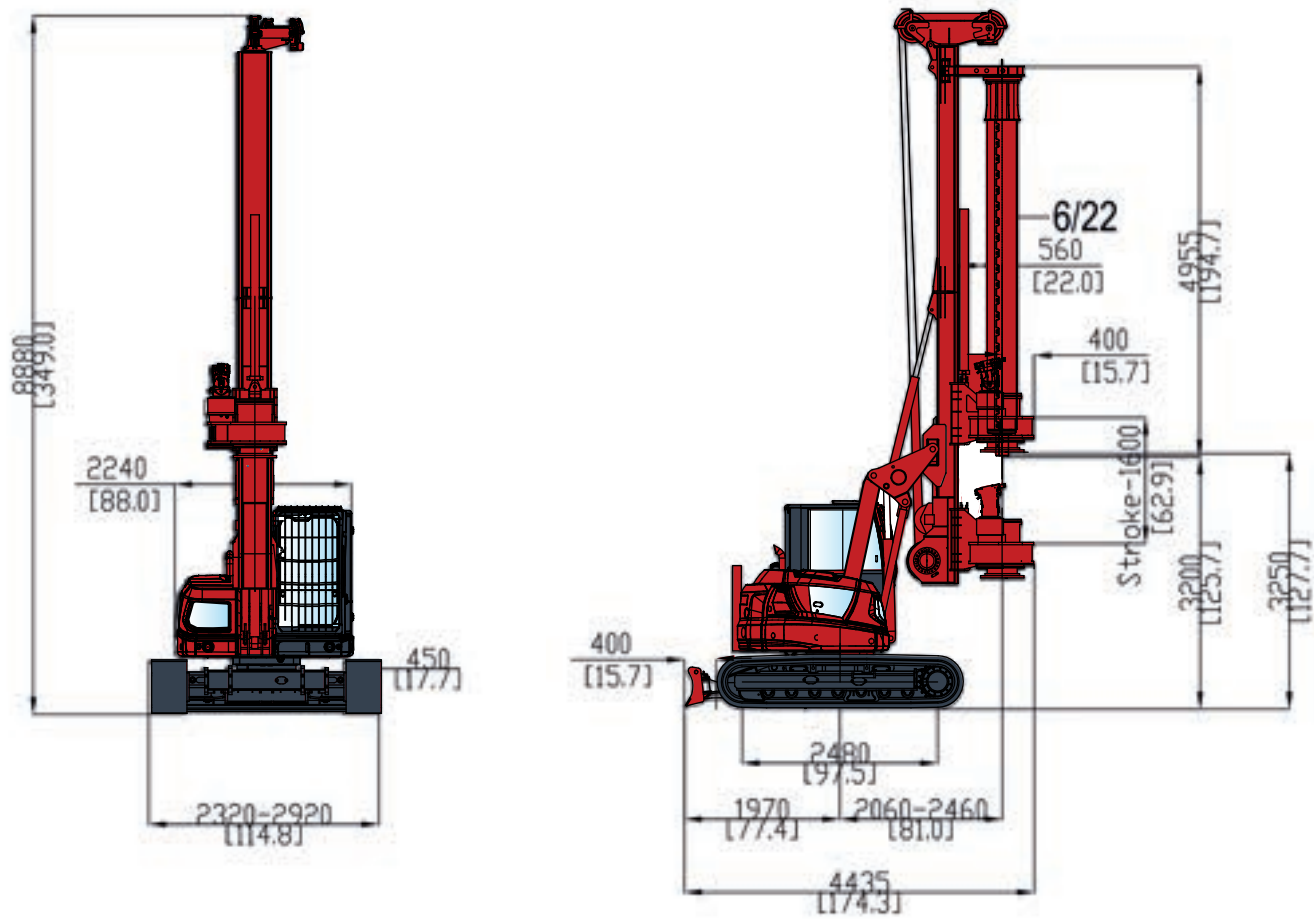

## Technical specifications

### A45 Crowd Cylinder

Rotary		
Installed torque	kNm	45
	lbf ft	33190
Min. Working speed	rpm	15
Max. Working speed	rpm	60
Min. Discharge speed	rpm	60
Max. Discharge speed	rpm	60

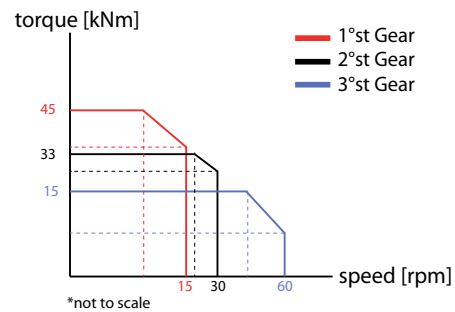

Winches		
Main winch nominal pull force	kN	55
	lbf	12360
Main winch speed	m/min	70
	ft/min	229
Main winch rope diameter	mm	16
	in	/
Auxiliary winch nominal pull force	kN	25
	lbf	5620
Auxiliary winch Speed	m/min	45
	ft/min	147
Auxiliary winch cable diameter	mm	12
	in	/

Crowd System		
Kelly crowd push	kN	60
	lbf	13490
Kelly crowd pull	kN	60
	lbf	13490
Stroke (mm)	mm	1600
	in	63

Base	IMT	
Undercarriage length/widening range/shoe	mm	3130/2920 - 2320/450
	in	123/115-91,3/17,7
Engine Type	YANMAR 4TNV98CT STV	
	53,7 kw (73 cv)@2100 rpm	
Oil tank capacity	l	90
Fuel tank capacity	l	105

Mast		
Mast raking forward	degree	4°
Mast side raking	degree	±5°
Mast raking backwards	degree	15°
Pile max diameter	mm	1100
	in	43

Kelly bar		
Standard		6/22
Options available		6/30-6/18
Operating Weight w/standard kelly bar	t(metric)	16,5
	lbs	36400



# A 45 - Hydraulic Drill Rig

## Working area A45 crowd cylinder

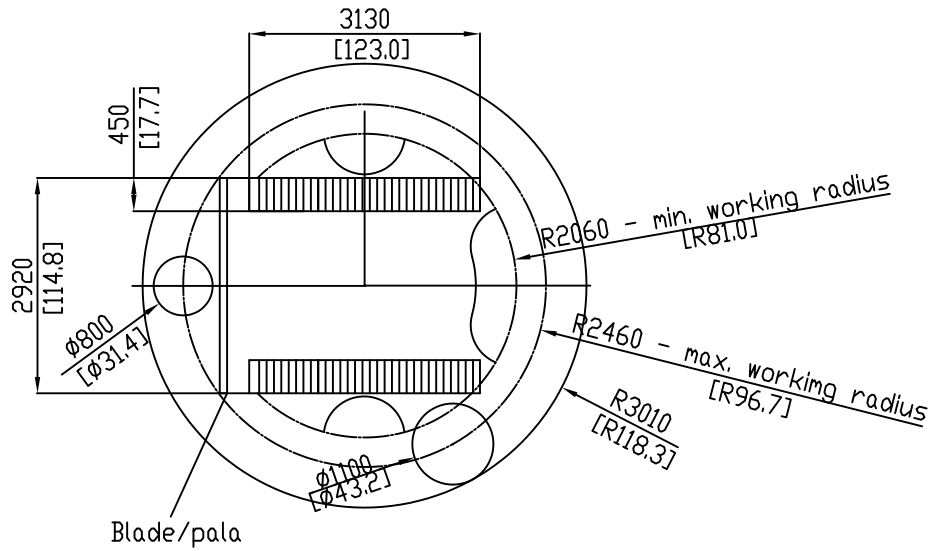

A	MAX WORKING RADIUS 2460
B	MAX TOOL DIAMETER Ø1100
C	MIN WORKING RADIUS 2060

## Equipment

### - STANDARD EQUIPMENT -

- Air conditioner
- Neutral lever (lock out) for all control
- Guard cat top
- Top cabin working lights
- Fuel refill pump
- Engine diagnostic system
- Main and auxiliary load sensing circuit
- Free flow during drilling phase
- Automatic bottom hole stop
- Depth measuring device on main winch
- Mast inclination measurement

### - OPTIONAL EQUIPMENT-

- Biodegradable oil
- Rear camera
- CFA kit
- Every kind of Kelly bar
- GPS kit
- Tier 4 final / Eu stage V engine

# A45 - Hydraulic Drill Rig

## Kelly bar standard version

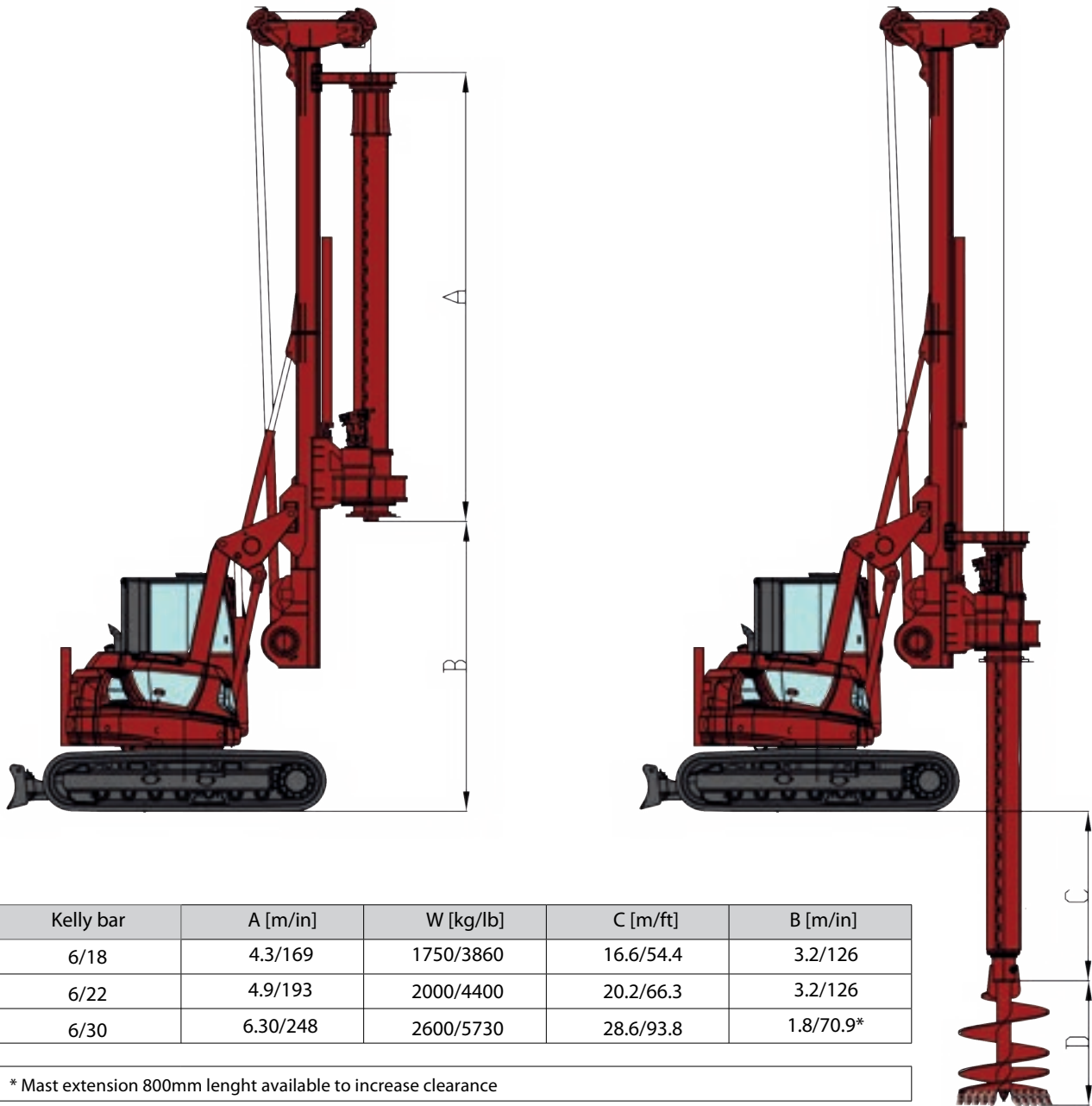

D	1,5 [m]	100x100 mm
Standard square joint 100x100 other dimension available		
Further kelly bars available on request		

# A 45 - Hydraulic Drill Rig

LCA version

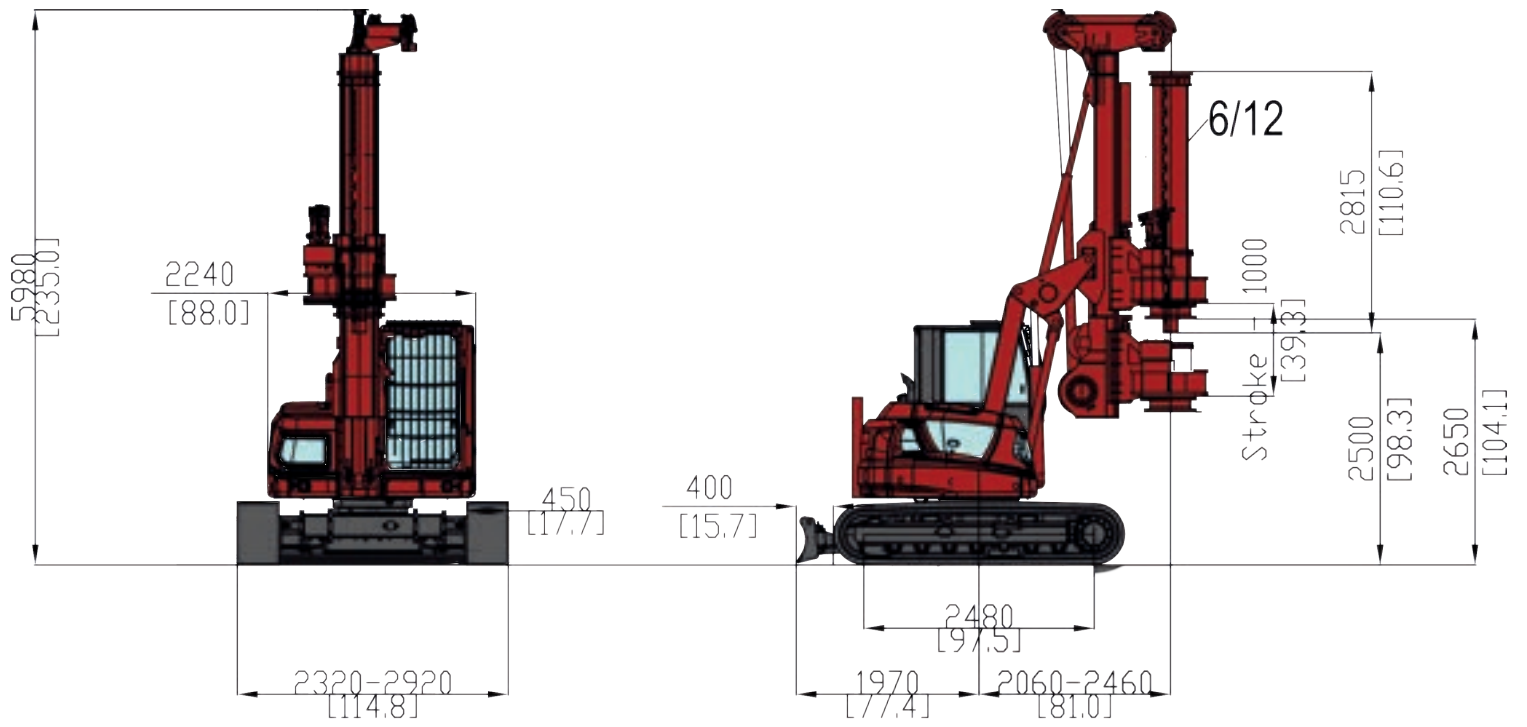

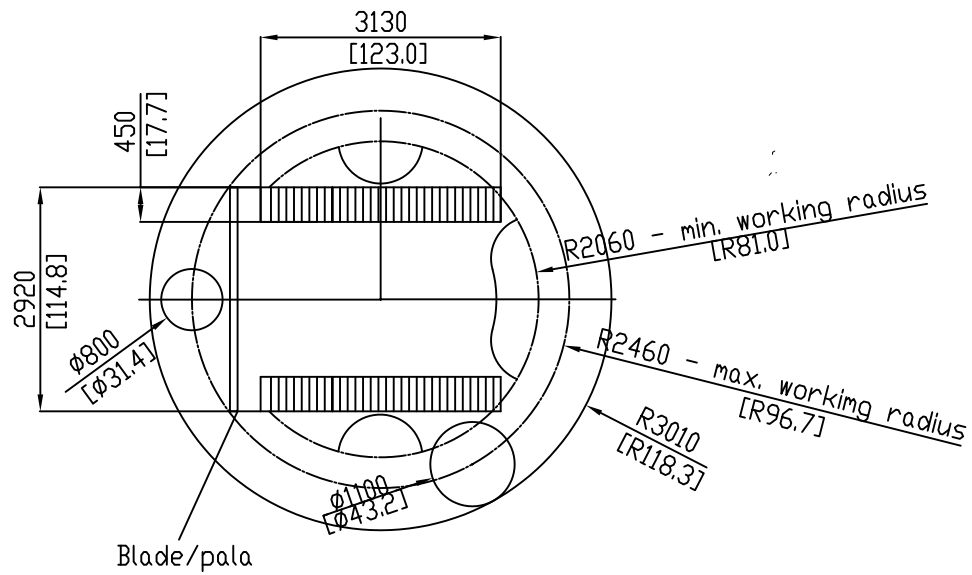

<b>A</b>	MAX WORKING RADIUS 2460 [R 97]
<b>B</b>	MAX TOOL DIAMETER Ø1100 [R 59]
<b>C</b>	MIN WORKING RADIUS 2060 [R 124]

<b>Cylinder Crowd System</b>		
Kelly crowd push	kN	60
	lbf	13490
Kelly crowd pull	kN	60
	lbf	13490
Stroke	mm	1000
<b>Mast</b>		
Pile max diameter	mm	1100
<b>Kelly bar</b>		
Standard		6/12
Options available		on request
Operating Weight w/standard kelly bar (5/20)	t (metric)	15
	lbs	33070



# A45 - Hydraulic Drill Rig

## CFA II Line Pull

<b>Rotary</b>		
Installed torque	kNm	45
	lbf ft	33200
Working speed	rpm	15-60
<b>Crowd system</b>		
Pulling nominal force (optional)	kN	20
	lbf	4496
Pushing nominal force	kN	110
	lbf	24730
Max pull/push speed	m/min	35
Rotary stroke	mm	8100
	in	319
Pull cable diameter	mm	16
	in	/
Drilling depth maximum w/o auger extension	m	7,6
	ft	25
Drilling depth maximum w auger extension	m	11,1
	ft	36,4
<b>Mast</b>		
Mast raking forward	degree	4°
Mast Side raking	degree	±5°
Mast raking backwards	degree	15°
Pile max. diameter	mm	500
	in	20
Operating Weight w/o auger	t(metric)	15
	lbs	33070

# A 45 - Hydraulic Drill Rig



## A 45 - Hydraulic Drill Rig



## Worldwide sales and assistance network



IMT dealers, a global network at your service  
IMT, like very few other companies in the field,  
has a global commercial and assistance network which is  
present in over 30 countries.  
From any part of the world IMT clients know which they  
can always count on fast and efficient service.



This document is created and distributed by IMT. This document may not be reproduced, modified or exhibited without authorization by IMT srl. All rights reserved. ©

All technical data are indicative and subject to change without notice.



**I.M.T. S.r.l. - Industria Meccanica Trivelle**  
via D'Ancona,39 60027 Osimo (AN) Italy  
Tel. +39 071 723341 - Fax +39 0717 133 352  
[imt@imtspa.com](mailto:imt@imtspa.com) - [www.imtspa.com](http://www.imtspa.com)