

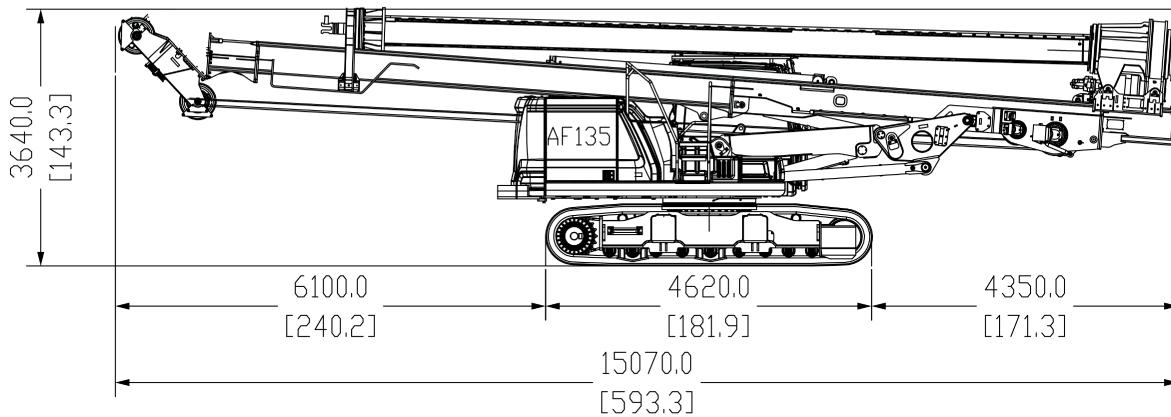

AF135



Base		CAT 323 NGH
Undercarriage length / widening range / shoe	mm	CAT 4620/2550 - 3650/600
	in	181/100 - 144/23,6
Engine type		CAT C 4,4 STAGE V
Power		129KW (173 HP) @1900 rpm
Rotary		
Installed torque	kNm	140
	lbf ft	104000
Working speed	rpm	7,5 - 27
Discharge speed	rpm	45 - 120
Winches		
Main winch pull force	kN	140
	lbf	31475
Main winch speed	m/min	80
	ft/min	262
Main winch Cable diameter	mm	22
	in	/
Auxiliary winch pull force	kN	60
	lbf	13490
Auxiliary winch Speed	m/min	40
	ft/min	131
Auxiliary winch Cable diameter	mm	15
	in	/
Crowd system		
Kelly crowd push	kN	100
	lbf	22485
Kelly crowd pull	kN	165
	lbf	37095
Stroke	mm	3500
	in	138
Mast		
Mast raking forward	degree	5°
Mast side raking	degree	±5°
Mast raking backwards	degree	15°
Pile max. diameter	mm	1500
	in	60
Kelly bar		
Standard		4/38
Options available		3/27 - 4/29 - 5/47
Operating Weight w/standard kelly bar	t	39
	lbs	85980

Measurements in working phase

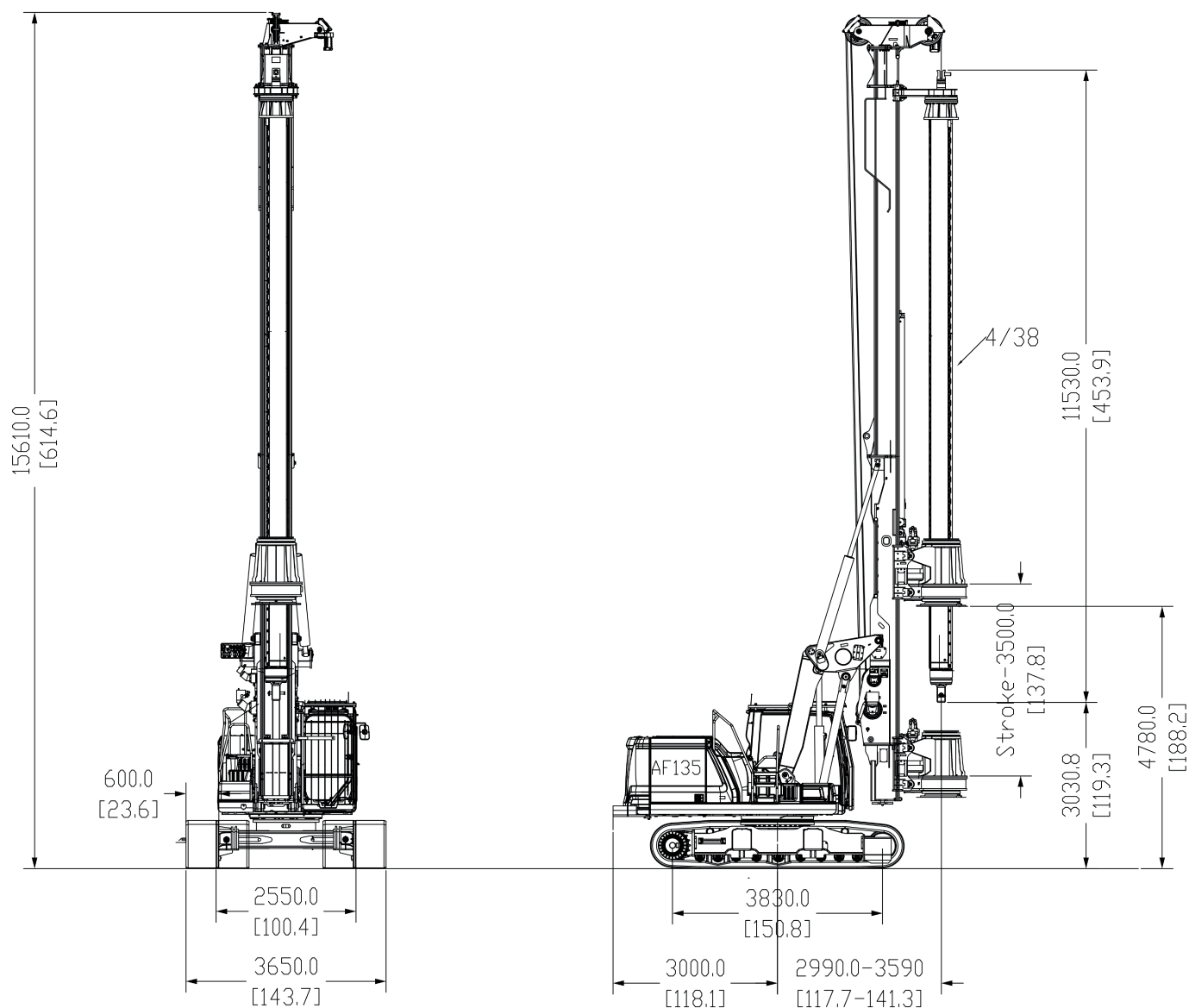

I.M.T. S.r.l. - Industria Meccanica Trivelle
 via D'Ancona, 39 60027 Osimo (AN) Italy
 Tel. +39 071 723341 - Fax +39 0717 133 352
 imt@imtspa.com - www.imtspa.com

All technical data are purely indicative and subject to change without notice.